

REV	ECN NO	DESCRIPTION	DATE	NAME
A	—	NEW	10/08-'23	LJS

- SPECIFICATION:
- MATERIAL & FINISH:SEE THE LIST;
 - PLATING SPECIFICATION:
 - CONTACTS:
 - Ni 50u" MIN. UNDER PLATED OVER ALL.
 - Au PLATED ON THE MATING AREA OF CONTACT.
 - Sn PLATED ON THE SOLDER AREA.
 - SHELL: Ni 30u" MIN. UNDER PLATED OVER ALL.
 - MID PLATE: CLEAR ONLY
 - MECHANICAL:
 - MATING FORCE: 0.5~2.0kgf;
 - UNMATING FORCE: 0.8~2.0kgf.
 - DURABILITY: 10000 CYCLES;
 - ELECTRICAL:
 - CURRENT RATING: 5A Max;
 - VOLTAGE RATING: 20V Max;
 - DIELECTRIC WITHSTANDING VOLTAGE: 100Vac;
 - CONTACT RESISTANCE: 40mΩ Ohms Max.;
 - INSULATION RESISTANCE: 100M Ohms Min.;
 - ENVIRONMENTAL:
 - OPERATING TEMPERATURE: -40° C~+85° C;
 - WETTING TEMPERATURE: 265±5° C, 5±0.5s
 - Salt Spray Test: 48H Min

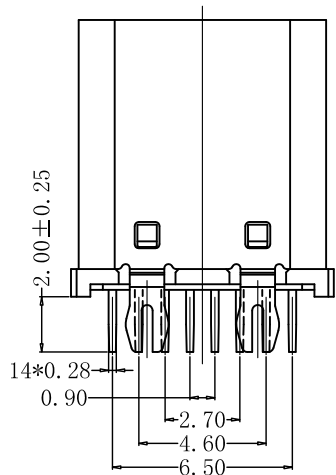

PIN DEFINE TABLE			
PIN	SIGNAL	PIN	SIGNAL
A12	GND	B1	GND
A11		B2	
A10		B3	
A9	VBUS	B4	VBUS
A8		B5	CC2
A7	D-	B6	D+
A6	D+	B7	D-
A5	CC1	B8	
A4	VBUS	B9	VBUS
A3		B10	
A2		B11	
A1	GND	B12	GND

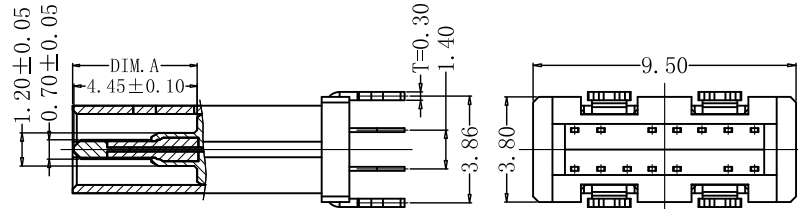
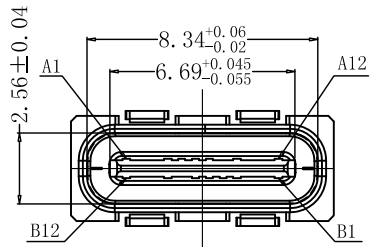
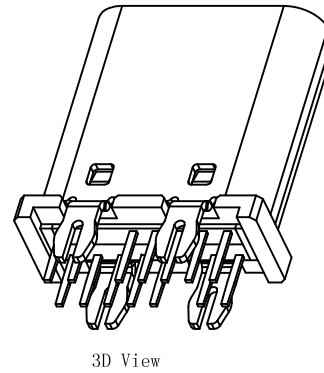
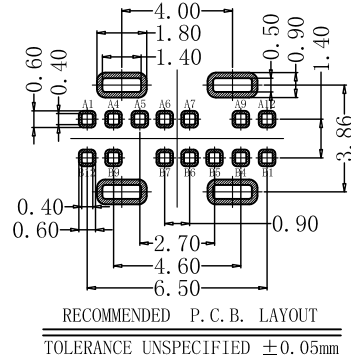
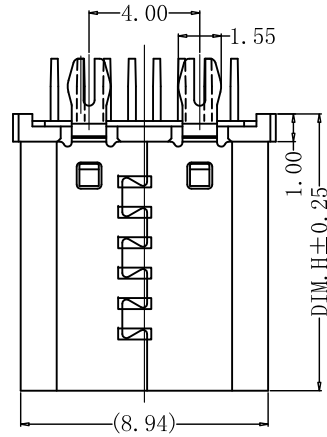
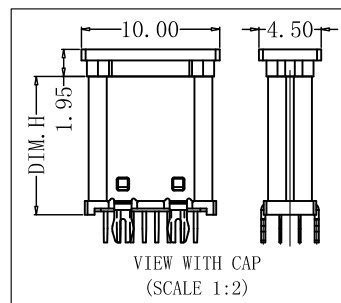

DIM. H	DIM. A
10.0	4.50
10.5	5.00

Ordering Information

LUB X XX X XXXX

- M:MALE
F:FEMALE
(不適用時 0表示)
- NO. of Pins Per Row: 01-99P
- Packing
A:袋裝
B:管裝
C:盤裝
D:卷裝
E:袋加盒
F:其它
- Serial NO. 0001-9999

NO.	PART NAME	Q' TY	MATERIAL	FINISH
4	Shell	1	Stainless Steel, T=0.30mm	30u"Ni Min.
3	GroundBar	1	Stainless Steel, T=0.15mm	No Plating
2	Contact	14	Copper Alloy, T=0.15mm	Au/Sn/Ni-Plated
1	Housing	1	High temperature plastic	UL94 V-0, Black

LDCONN 东莞连大精密制品有限公司
DongGuan LianDa Precision Products Co., LTD

STANDARD TOLERANCE (EXCEPT SPECIFIED)	
LINER	ANGLES
.0 ±0.30	0.° ±3°
.00 ±0.20	.0° ±2°
.000 ±0.10	.00° ±1°

TITLE	TYPE-C 14PIN 直立贴 DIP型 母座 带定位鱼叉 H10.0	DRAWN BY	LJS	10/08-'23
PART NO.	LUBF14D0001	CHECKED BY		
DRAWING NO.	—	APPROVED BY		
SCALE	1:1	UNIT	mm	PAGE 1/1
				SIZE A4